

LPA CONNECTION SYSTEMS

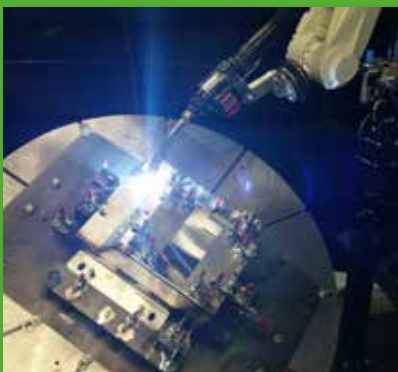

Long Life Reliability
does not cost the earth



CONNECTION SOLUTIONS
FOR RAILWAY ROLLING STOCK

www.lpa-connect.com



10 Gbit/s ETHERNET TECHNOLOGY



ETHERNET SWITCH

ELECTRICAL CABINETS

CONNECTION BOX

STARTER BOX



INTER-CAR JUMPERS

POWER

CONTROL



HYBRID

DATA



EARTH BONDING

EARTH STUDS



EARTH STRAPS



10 Gbit/s ETHERNET TECHNOLOGY

SWITCHES



BACKBONES



HARNESSES

CONTROL



CONTROL & DATA



CCTV

WIFI

PASSENGER
COUNTING

PASSENGER
INFO SYSTEM

ETHERNET BACKBONE

BATTERY RAFTS

MAINLINE



METRO



UNDER-FRAME BOXES

ELECTRICAL CABINETS



CONNECTION BOX



CIRCUIT BREAKER



ADAPTOR BOX



SHORE SUPPLY

3-PHASE



1-PHASE

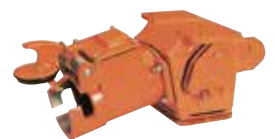



CONTENTS

INTER-CAR JUMPERS & CONNECTION SYSTEMS

Overview	4
Jumper Systems	5
Vehicle End, Underframe & Equipment Cabinets	6

10 Gbit/s ETHERNET TECHNOLOGY

Overview	7
10GBASE-T Capability	8
10 Gbit/s Ethernet Switches	9

HARNESSES & TERMINAL RAILS

Overview	10
Harnesses & Terminal Rail Assemblies	11
Earth Studs & Earth Straps	12

CONNECTIONS FOR AUXILIARY SYSTEMS

Overview	13
Battery Rafts & Niphan Connections	14
Shore Supply	15

IN-HOUSE CAPABILITIES

Overview	16
Robust Validation	17
Vertically Integrated Manufacturing	18



Bespoke Designs for Robust Applications

Inter-car Jumpers & Connection Systems

Jumper Systems, Underframe Connections & Equipment Cabinets



- Hybrid Jumper range provides combined power and data transfer
- Ingress Protection up to IP66, IPx7
- Multiple power options available
- Ethernet: up to 10 Gbit/s

JUMPER SYSTEMS

RECEPTACLE

The hybrid flange mounted receptacle is normally body end mounted and is provided with spring clips or bolts as retaining method for securing the plug to the receptacle. When the plug is not fixed a spring operated cover maintains the integrity of the fitting to IP66. Dummy receptacles are available for plug storage purposes.

PLUG

A compact robust plug with a versatile range of planforms that enable the use of both data and power contacts. The plug can accommodate both composite cables and conduited cable solutions and ensures a complete IP66, IPx7 seal when mated with the receptacle.

JUMPER SYSTEMS

LPA Inter-car Jumpers are installed in over 10,000 UK Rail vehicles in service today.

A common source of potential water ingress is from inside the coach not between plug and receptacle. To combat this LPA have chosen a sealant that provides a watertight seal that also promotes ease of maintenance.

Applications

LPA's range of jumper systems are compatible with our under-frame boxes. The bespoke connectors can incorporate power, control and data capabilities providing a hybrid solution which reduces the number of jumper systems. LPA's 4S-10G™ connectors have been fitted to Metro and Mainline trains since 2009 and there have been no connectivity losses.

Range

Designed for multiple applications, in response to diminishing space envelopes:

Mod 22: A hybrid connector combining power, control and data capabilities

Mod 32: A hybrid connector combining power, control and data capabilities

Mod 42: A hybrid connector combining power, control and data capabilities

Mod 52: A hybrid connector combining power, control and data capabilities

Features

- Power:
 - 1-Phase or 3-Phase, with Auxiliary Power circuits
- Control:
 - Module 32: up to 19 contacts
 - Module 42: up to 61 contacts
 - Module 52: up to 108 contacts
- Data:
 - Ethernet, up to 10 Gbit/s
 - Co-Ax, Tri-Ax RF connectors
 - Microwave
- Fixings: Bolted or clipped
- Termination: crimped
- Operating Temperatures: -40°C to +70°C
- Ingress Protection to IP66

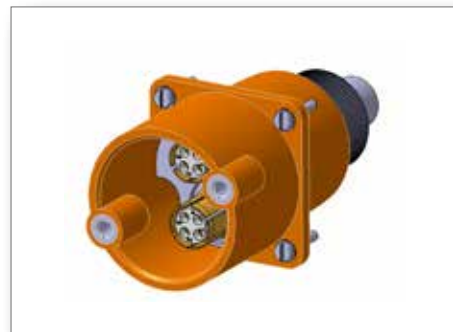

VEHICLE END, UNDERFRAME & EQUIPMENT CABINETS

VEHICLE END/UNDERFRAME BOXES

Features

- Bespoke designs to fit available space envelope within vehicle body end
- Available in mild steel, stainless steel or aluminium
- Finish in low smoke and low toxicity polyester paint, as required
- Standard connects to interface with internal harness
- LPA's Railway connectors provide rugged car connections
- Ingress Protection: up to IP66, IPx7
- Shock and Vibration: tested to EN 61373



ELECTRICAL EQUIPMENT CABINETS

Features

- Mild steel or stainless steel enclosure
- Bespoke design to match customers specification and space envelopes
- Mountings to suit vehicle
- Wiring to mainline or LUL standard per customer requirements
- Ingress Protection: up to IP66, IPx7
- Low smoke and halogen free to EN 45545 and BS 6853





Long Life Reliability
does not cost the earth

10GBASE-T capability

Future proofed
technology

357 031

10 Gbit/s Ethernet Technology

10GBASE-T Compatible



- Incorporated into our range of standard rail connectors
- Offers combined data and communication transmission across inter-car gaps
- Compatible with existing Railcat Ethernet cables
- Enables Wi-Fi service provision
- Provides backbone for High Definition CCTV

ETHERNET CONNECTORS

ETHERNET 10GBASE-T CAPABILITY

LPA has standardised its 1 Gbit/s and 10 Gbit/s connectors and cabling to ensure future proofing up to 10 Gbit/s. As such, each connector must be cabled with 2x Cat 5 tin plated cables, with cross-sectional area of 0.5mm².

The Module 22, 32, 42 & 52 Jumpers are high quality, rugged and robust connector ranges designed specifically for the rail market. In order to provide fast Ethernet speeds of 10GbE, 2x 4S-10G™ connectors are required within the jumper.

LPA Ethernet Cable Flex Testing found Cat 5e cables were the most robust cables for Jumpers, able to withstand the continual

flexing faced during lifetime as an inter-car jumper. As such, LPA recommends the installation of Cat 5e cables for inter-car gaps, and Cat 7 cables for fixed, intra-car harnesses. This configuration ensures reliable data transfer across the product life-time, while reducing ownership cost.

Under EMC immunity testing, data transmission through LPA's 4S-10G™ connectors was unaffected by control circuits in a Hybrid Data & Control Jumper.

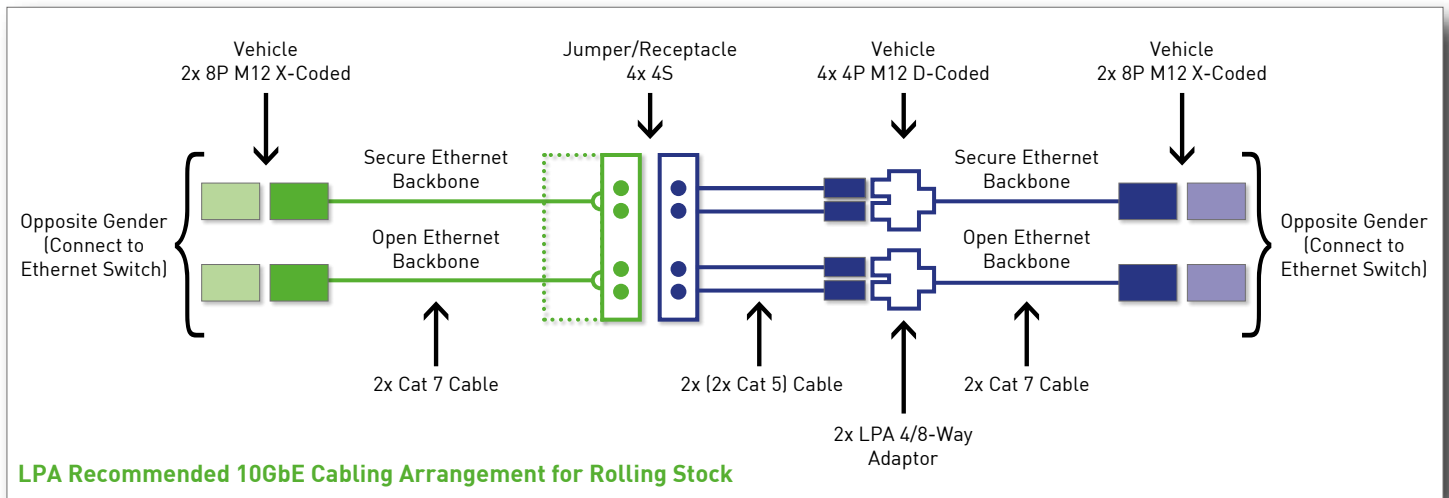

10 Gbit/s ETHERNET SWITCHES OVER COPPER

LPA's Ethernet Switches can discover the current IP address and ensure any replaced car is assigned with the proper IP address of the original topology without resetting. Furthermore, Link Train Discovery Protocol allows the replaced switch to inherit all the configuration of the old switch too.

LPA's 10 Gbit/s Ethernet Switches incorporate smart bypass technology. Smart bypass enables the system to bypass any malfunctioning or deactivated switches in order to prevent system failure.

Our bespoke designs can be ordered with 5 to 24 ports, PoE/ non-PoE, 100 Mbit/s, 1 Gbit/s, 10 Gbit/s and 12V, 24V, 72V, 110V, Wide Voltage power inputs.

Features

- Aluminium housing is lightweight and oxidation resistant to ensure high performance and stability
- Prioritisation of different data streams
- Automatic re-routing of Ethernet Backbone if primary backbone fails
- Bypass relay
- EN50155/EN45545-2 certified
- Operating Temperature range: -40°C to 75°C
- 10GBASE-T Compatible Switches and Connectors
- Port to upload & download configuration files



ETHERNET CAPABILITY

10GbE HARNESS

10GBASE-T performance offers high bandwidth and future proofed installations using copper coating, for maximum reliability and robustness in harsh rolling stock applications.

LPA have also designed a 4/8-Way Adaptor as shown overleaf, to enable connectivity between 2x Cat 5e inter-car cables and 1x Cat 7 harness cables.

Features

- High bandwidth availability, ensuring passenger safety and security, enabling:
 - always on CCTV
 - failover capability
 - enables passenger information services
 - high speed Wi-Fi connectivity
 - seat occupancy
 - next station information
 - provides a backbone for seat occupancy notifications
 - seat locator
 - seat occupied/unoccupied



10GbE INTER-CAR JUMPERS FEATURES

- 4 contacts plus screen: 4S-10G™
- Transmission rates: up to 10 Gbit/s
- 100 Ω up to 600 MHz
- Modular design compatible with LPA interiors
- Compatible with RAILCAT Cat 5 & Cat 5e cables
- EMC certified:
 - EN 50121-3-2: 2006 & BS EN 61000-4-3
 - RIA 12: Clause 11
- Standard or Bespoke to suit customer requirements



Features

- Train-to-Shore communications
- Passenger Wi-Fi
- Infotainment & Media
- HD CCTV
- Passenger Information Systems
- Passenger Counting
- Radio Frequency Systems





Bespoke solution to suit customer requirements



Harness Solutions

Harnesses, Terminal Rail Assemblies & Earthing Components



- Railway approved to current and legacy standards - including fire
- Automatic cable cutting machinery enabling accurate and cost effective manufacture
- Variety of cable available to meet specification compliance
- Complex branching to meet vehicle design layout
- Wire identification to meet individual requirements
- Up to 50m in length cable harness

HARNESSES & TERMINAL RAIL ASSEMBLIES

HARNESSES AND LOOMS

Features

- Available up to 50m in length
- Connectors fitted to suit requirements
- Automatic cable cutting machine for accuracy and cost effective manufacture
- Wire IDs to meet customers requirements
- Cable selected to comply with specification
- Complex branching to match vehicle layout
- Low smoke and halogen free to EN 45545 and BS 6853



TERMINAL RAIL ASSEMBLIES

LPA Connection Systems terminal blocks are manufactured from proven designs and have been used in applications throughout the United Kingdom, Europe, America and the Far East.

The terminals are Grade 8.8 steel offering a consistently high quality thread. Rail assemblies are suitable for overground, underground and tunnel/ channel tunnel applications.

Features

- Supplied fully assembled or as loose components
- Metric sizes and UNC options are available
- M4 to M12 studs
- Fused and push-on terminals
- 5-way faston
- Integral fixing bolts or brushes for rapid installation.
- Low smoke and halogen free to EN 45545 and BS 6853

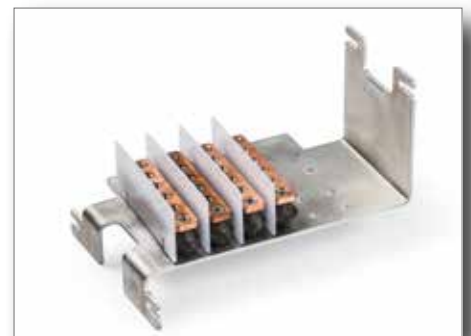

EARTH STUDS & EARTH STRAPS

EARTH STUDS

LPA Earth Studs are manufactured from the highest material quality and designed to maximise the conduction of electricity through mild and stainless steel.

These studs are suitable for welding or brazing to enclosures or structures of the same material to avoid galvanic corrosion issues and are available in a number of sizes to suit various fault currents.

Features

- Mild and Stainless Steel variants
- Suitable for welding
- 6 sizes from M6 up to M20
- Brass electrical connection parts, silver soldered to parent material
- Provided with high temperature protective washer (to be removed post welding and painting)
- Rail industry approved and proven
- Soft solder tinning to mating surface ensures conformal contact to terminal lugs



EARTH STRAPS

LPA Earth Straps are designed and manufactured to provide a highly reliable, flexible earth bond on trains and rolling stock.

Earth straps are typically used to provide earth bonding between cabinet-to-body and bogie-to-body, suitable for conducting fault currents. Our earth straps can be custom made to your requirements and can be ordered with in-line flat, in-line angled or 90° lugs.

Features

- High integrity electrical continuity for effective earth bonding capabilities
- Tin plated copper lug terminals suitable for high current ratings.
- Straps are provided with hexagonal crimps
- Fully sealed between lug and cable to prevent water ingress corrosion and mechanically support of cable at termination to protect the conductors
- Flexible and easily laid in multiple directions
- Variable terminal offset angle
- Rail industry approved and proven





Long life & low
maintenance

Space Saving

Auxiliary Systems

Battery Rafts, Connectors & Electric Train Supply/Shore Supply



- Ingress Protection up to IP66, IPx7
- Low Smoke and Toxicity PMC interiors
- Bespoke design to suit customer specific applications requirements
- Tailor-made to fit space envelope
- Connects to interface with internal harness

BATTERY RAFTS & NIPHAN CONNECTORS

BATTERY RAFTS

Features

- Optimised to fit within available under-frame space envelope, ensuring easy access to componentry for fast maintenance
- Available in mild steel, stainless steel or aluminium
- Finish in low smoke and low toxicity polyester paint (if required)
- Standard connects to interface with internal harness
- LPA's Railway connectors provide rugged car connections
- Delivery on transportation jig, direct to customer's assembly line
- Ingress Protection: up to IP66, IPx7
- Shock and Vibration: tested to EN 61373



AUXILIARY CONNECTORS

Features

- Enables quick release of power and control connections to auxiliary systems
- Durable electroless nickel-plated brass casing
- Up to 500 V and 200 Amps
- Up to 12 poles
- Operating temperature: -40°C to +70°C
- Ingress Protection: up to IP66, IPx7
- Fire Performance:
 - EN 50200 PH120 & BS 8434-2
 - BS 6853 (C, W, Z)
 - NFF 16-101
- Shock and Vibration: tested to EN 61373



SHORE SUPPLY

ELECTRIC TRAIN SUPPLY

Features

- Train power functions
- Industry leading space saving functionality and life time performance
- Wide range of AC and DC voltages up to 1.5 kV AC and 3 kV DC
- High current capability up to 800 Amps
- Multiple keyway protection
- Multiple electrical interlock options
- 3-Phase circuit protection breaker option
- Enclosures manufactured in stainless steel, mild steel and aluminium at LPA's state of the art facility
- Ingress Protection: up to IP66
- Interiors moulded in house with Low Smoke and Toxicity PMC

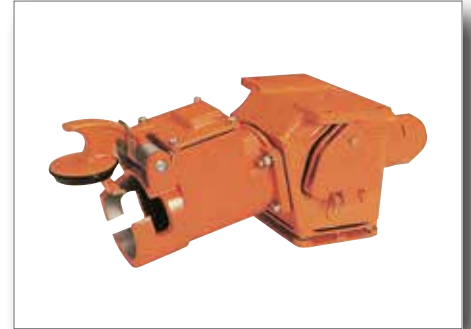

SHORE SUPPLY

Shore Supplies are used for connecting power to trains when they are stabled or being maintained in depots and workshops. They are also used to provide power for battery charging.

Features

- Industry leading space saving functionality and life time performance
- Train power and battery power functions
- Wide range of AC and DC voltages
- Multiple keyway protection options
- Multiple electrical interlock options
- 3-Phase circuit protection breaker option
- Enclosures manufactured in stainless steel, mild steel and aluminium at LPA's state of the art facility
- Ingress Protection: up to IP66
- Interiors moulded in house with Low Smoke and Toxicity PMC





Vertically integrated manufacturing capabilities

Vigorous validation

In-House Capabilities



LPA has over 40 years experience in the Rolling Stock Connection Systems industry and offers solutions throughout the production process.

From design to manufacture, through to complete assembly, our in-house knowledge, design, and equipment enables timely delivery of complex projects.

RIGOROUS TESTING

FINITE ELEMENT ANALYSIS

- Preliminary Finite Element Analysis (FEA) utilised to optimise design, reduce mass where possible and select optimum materials
- Formal FEA conducted by 3rd party in line with customer requirements, including maximum stresses and resonance frequency sweep

STATIC MOCK-UP

- LPA always recommend conducting a physical mock-up of any new or revisited jumper installation. Physical mock-up is based on inter-vehicle geometry and track geometry, representing movements experienced by the fleet over nominated routes, (switches/crossings and curves)
- The mock-up is used to determine correct jumper length and exit/entry angles while ensuring any gauge requirement is not infringed
- Mock up also ensures that:
 - jumpers are not unduly strained or stretched
 - minimum bend radii requirements are observed
 - jumpers do not clash with each other or nearby projections
- Physical mock-up ensures long life reliability

DYNAMIC LIFE TEST

- Dynamic testing of jumpers and associated equipment on the LPA in-house 2-axis dynamic test rig
- Testing based on track geometry, representing movements experienced by fleet over nominated routes, switches/crossings and curves
- Represents a day-in-the-life of the train
- Number of cycles agreed with customer to represent jumper life span
- Testing validates LPA mock-up (or customer design) and verifies that jumpers are of the correct length and are not unduly stressed through their expected life

SHOCK & VIBRATION TESTING

- Independent certification obtained to ensure reliable operation in the hostile environment of rolling stock service
- Shock and vibration third party testing conducted to EN 50155

INGRESS PROTECTION

- Independent certification to ensure reliable operation in hostile environments
- Ingress protection conducted to IEC 60529

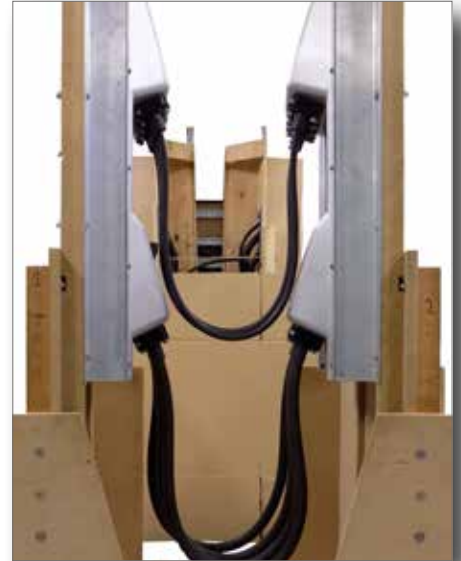

VERTICALLY INTEGRATED MANUFACTURING

3D CAD MODELLING



FINITE ELEMENT ANALYSIS
(NATURAL FREQUENCY-DISPLACEMENT)

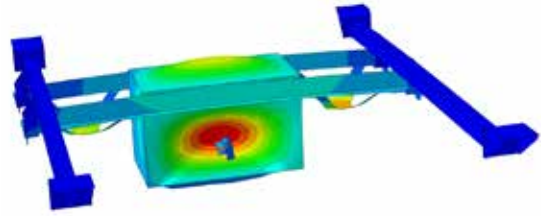

IN-HOUSE
CNC MACHINING



ROBOTIC WELDING

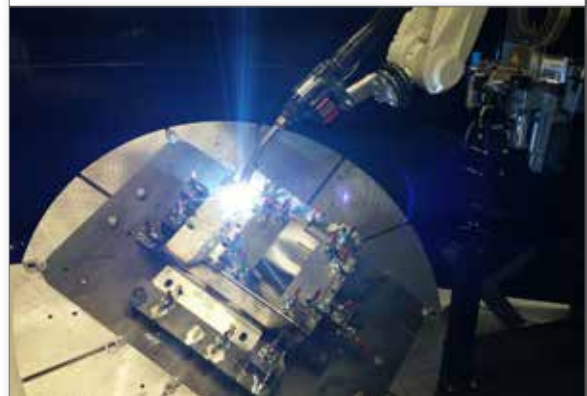

AUTOMATIC CABLE
CUTTING & PREPARATION



CIRRIS™ AUTOMATIC
TEST EQUIPMENT





Long Life Reliability
does not cost the earth

www.lpa-connect.com



LPA GROUP PLC

Light & Power House,
Shire Hill, Saffron Walden,
CB11 3AQ, UK
Tel: +44 (0)1799 512800
Email: enquiries@lpa-group.com

LPA CHANNEL ELECTRIC

Bath Road, Thatcham,
Berkshire, RG18 3ST. UK
Tel: +44 (0)1635 864866
Email: enquiries@lpa-channel.com

LPA LIGHTING SYSTEMS

LPA House, Ripley Drive,
Normanton, West Yorkshire,
WF6 1QT. UK
Tel: +44 (0)1924 224100
Email: enquiries@lpa-light.com

LPA TRANSPORT +®

Light & Power House,
Shire Hill, Saffron Walden,
CB11 3AQ, UK
Tel: +44 (0)1799 512800
Email: enquiries@lpa-connect.com

LPA CONNECTION SYSTEMS

Light & Power House,
Shire Hill, Saffron Walden,
CB11 3AQ, UK
Tel: +44 (0)1799 512800
Email: sales@lpa-connect.com



FM 01660



For further information please contact:

LPA CONNECTION SYSTEMS

Light & Power House,
Shire Hill, Saffron Walden,
CB11 3AQ, UK
Tel: +44 (0)1799 512800
Email: sales@lpa-connect.com

LPAPub.No.088/0918/250

Designed & produced by Hornett's Design Ltd - Linda@hornettsdesign.co.uk